

STONERIDGE DIGITAL KIT 7800-053



VEHICLE MANUFACTURER	FORD
MODEL	TRANSIT
YEAR OF MANUFACTURE	2006 ON
ENGINE TYPE	DIESEL
TRANSMISSION	MANUAL 6 SPEED RWD
VOLTAGE	12V



PARTS LIST	QUANTITY
TACHOGRAPH	1
SENDER	1
SENDER CABLE	1
TACHO MOTION KIT	1
INSTALLATION KIT	1
APPLICATION SHEET	1

ADDITIONAL VEHICLE MANUFACTURERS PARTS FOR DASH MOUNT POD	QUANTITY & PART NUMBERS
FORD DASH MOUNTING POD (FOUR PARTS)	1X 1448251
	1X 1424741
	2X 1431090
	2X 4067632

FITTING INFORMATION

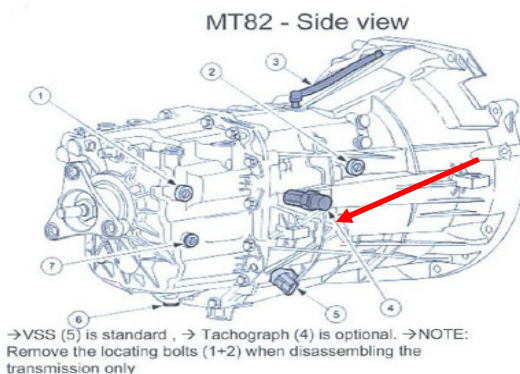

IMAGE LEFT SHOWS POSITION TO INSTALL 9954-256 SENSOR. SUITABLE POWER AND GROUND CONNECTIONS CAN BE TAKEN FROM THE VEHICLE FUSEBOX.

T-LIGHT MUST BE FITTED AS PER DVSA REQUIREMENTS ON PAGE 3 OF THIS SHEET IF THE TACHOGRAPH IS TO BE INSTALLED IN A DVSA AMBER LOCATION.

Workshop Technical Support

Tel +44 (0) 1382 866 700

Fax +44 (0) 1382 866 401

Email workshop.support@stoneridge.com

Sales Office

Tel +44 (0) 1382 866 400 (choose opt.1)

Fax +44 (0) 1382 866 401

Email sales@stoneridge.com



Whilst we have endeavoured to ensure the accuracy of the information supplied, Stoneridge Electronics cannot be held responsible for any errors or omissions. It is the installer's responsibility to ensure compliance with specific vehicle manufacturers repair procedures, especially with regard to the procedure for disconnection/reconnection of the battery. Failure to comply with the vehicle manufacturers instructions may result in personal injury and/or component damage/data loss.

DIGITAL APPLICATION SHEET



1. The 2nd Source of motion is obtained by using the GPS Module and cable harness, as shown above.

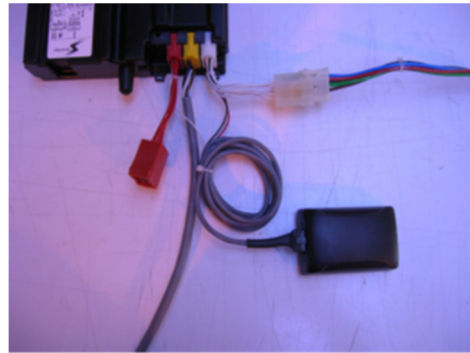

2. The cable harness is connected directly in line with the tachograph power cable when connecting to the tachograph as shown.



3. The GPS Module should be placed in a suitable area within the cab, preferably in an area next to the windscreen.

C3-Factor	Minimum L	Maximum L
13	1563	1688
14	1688	1813
15	1813	1938
16	1938	2063
17	2063	2188
18	2188	2313
19	2313	2438
20	2438	2563
21	2563	2688
22	2688	2813
23	2813	2938
24	2938	3063
25	3063	3188
26	3188	3313
27	3313	3438
28	3438	3563

4. Set the IMS input to C3 enable in MKIII Programmer, Sensor Settings and set the Speed Factor to correct C3 Factor value using the L factor table above.

Workshop Technical Support

Tel +44 (0) 1382 866 700

Fax +44 (0) 1382 866 401

Email workshop.support@stoneridge.com

Sales Office

Tel +44 (0) 1382 866 400 (choose opt.1)

Fax +44 (0) 1382 866 401

Email sales@stoneridge.com



Whilst we have endeavoured to ensure the accuracy of the information supplied, Stoneridge Electronics cannot be held responsible for any errors or omissions. It is the installer's responsibility to ensure compliance with specific vehicle manufacturers repair procedures, especially with regard to the procedure for disconnection/reconnection of the battery. Failure to comply with the vehicle manufacturers instructions may result in personal injury and/or component damage/data loss.

DIGITAL APPLICATION SHEET



Stoneridge T-light kit No. 7800-217.



Included in the kit is the LED light shown plus a T-sticker to apply to the LED

The red lead is connected to the D3 pin of the VU which is a +Ve supply and the black lead is connected to the D4 pin of the VU which is a general warning output. Both are connected via a brown mini-timer plug. (not supplied)

For the T-light to operate correctly, the VU pin D4 Pin function must be set to 'DTC Active'- Enable. This can be done using either the Stoneridge Optimo tool or the MKII programmer.

With the D4 set correctly the T-light will switch on when the VU detects DTC's

Once the T-light warning has been acknowledged by pressing the OK button, the T-light will remain ON for around 1 minute before switching OFF.

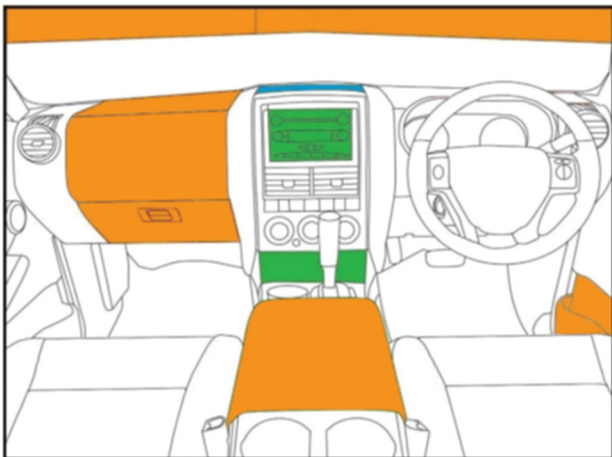

DVSA considers that the **amber** area is acceptable if the visual T-light is situated in the driver's field of vision both by day and by night.

DVSA considers that fitting a VU in any of the **green** areas is acceptable.

The **blue** area is acceptable if the location does not obscure the driver's view of the road.

Fitment under the driver's or passenger's seat is never acceptable

Workshop Technical Support

Tel +44 (0) 1382 866 700

Fax +44 (0) 1382 866 401

Email workshop.support@stoneridge.com

Sales Office

Tel +44 (0) 1382 866 400 (choose opt.1)

Fax +44 (0) 1382 866 401

Email sales@stoneridge.com



Whilst we have endeavoured to ensure the accuracy of the information supplied, Stoneridge Electronics cannot be held responsible for any errors or omissions. It is the installer's responsibility to ensure compliance with specific vehicle manufacturers repair procedures, especially with regard to the procedure for disconnection/reconnection of the battery. Failure to comply with the vehicle manufacturers instructions may result in personal injury and/or component damage/data loss.